

# **Tips for choosing the right Harman pellet stove**

Within this brochure there are some general guidelines that will help you choose the right pellet stove model for your home. Also you will find helpful tips for locating the stove so that you will receive the most warmth and comfort.

Below is a table of contents to help you quickly find the topics and answers to your “burning” questions.

Thank you for taking the time to consider Harman Pellet Stoves.



## **TABLE OF CONTENTS:**

<b>Zone Heating Advantages</b>	<b>Page 2</b>
<b>Harman’s Smart Technology</b>	<b>Page 3</b>
<b>Common Applications for Harman Pellet Stoves</b>	<b>Page 4</b>
<b>How Large a Stove is Necessary</b>	<b>Page 5</b>
<b>Stove Sizing Chart</b>	<b>Page 6</b>
<b>Other Factors to Consider</b>	<b>Pages 7 &amp; 8</b>
<b>Chimney Venting</b>	<b>Pages 9 - 11</b>
<b>Partial Venting</b>	<b>Page 12</b>
<b>Direct Vent Wall Pass Through Kit</b>	<b>Page 13</b>
<b>Important Tips and Considerations</b>	<b>Pages 14 – 16</b>
<b>Vent Termination Requirements</b>	<b>Page 17</b>

## Zone Heating – What is it and why is it so effective?

Pellet stoves are called “zone heaters” because they warm the area within the room and around the stove rather than the perimeter walls as most central heating systems do. This is a very energy efficient and comfortable way to heat because there are warm and cozy living areas and cooler outlying bedrooms for sleeping.

To maximize the effectiveness of zone heating each Harman pellet stove is equipped with a convection fan that draws in cooler air at the base of the stove. The air is then moved over large heat exchangers within the stove where it is heated before entering the room. This moving, heated air assists in creating natural convection loops that enable a single stove to heat a large area.

In addition, radiant heat from the stove warms you like the sun on a cold winter day. By using a stove for zone heating in place of your central heating, you may save up to 25% of your heating costs according to some industry experts, even if the price you are paying for pellets is the same per BTU as for oil or gas. Zone heating is more economical because you heat the living space, rather than the walls of your home.

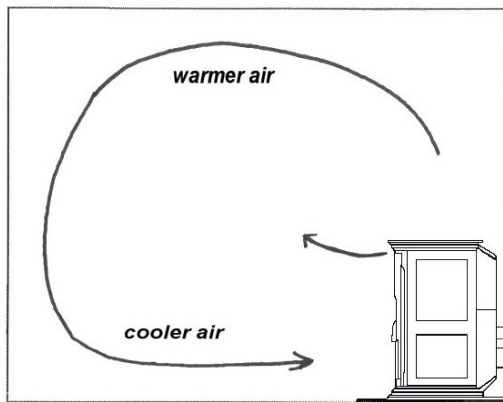

*Convection air flow in one room*

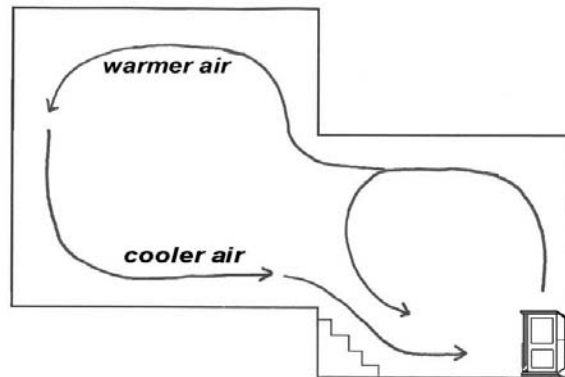

*Convection air flow in two rooms on two levels*

## Harman's Smart Technology:

Harman's "smart" technology gives you greater flexibility when choosing the ideal location within your home because the stove adjusts heat output to match the size of the area that is being heated.

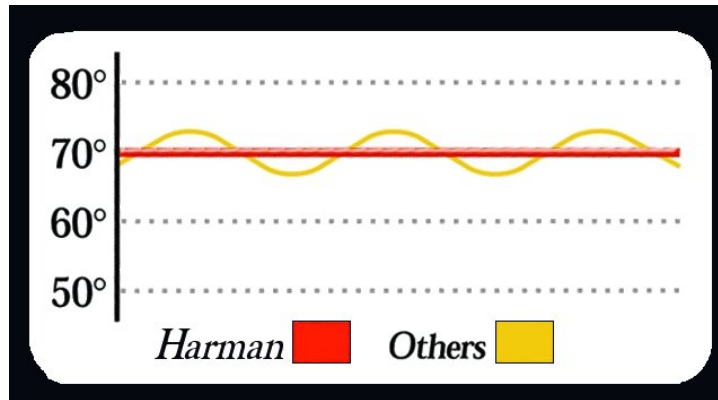

Harman pellet stoves are particularly effective zone heaters because they produce very even heat output and temperature fluctuations are greatly reduced. Gas stoves and woodstoves as well as many central heating systems cycle on and off so that ambient temperatures may be either too high or too low. By controlling the temperature precisely, you conserve energy and experience a higher level of comfort. Harman's microprocessor controlled pellet stoves take this concept further by constantly monitoring room temperature and automatically increasing or decreasing heat output to match the heat loss of your home. This precise control and remarkably steady heat give Harman pellet stoves the "comfort" advantage over gas and woodstoves and other pellet stoves on the market.

Harman's "smart" technology pellet stoves will actually turn themselves off when no heat is required and relight when heat is needed. This fully automatic feature lets you use the stove during the spring and fall months when temperatures are warm during the day and cold at night without overheating the area. Harman's "smart" technology gives you greater flexibility when choosing the ideal location for your home because the stove adjusts heat output to match the size of the area that is being heated. Most other brands of pellet stoves and all woodstoves have minimum burn rates which often overheat the rooms that they are in.

When you need serious heat Harman pellet stoves offer the highest outputs of any pellet stoves on the market. Due to careful design these stoves are capable of operating continuously at high heat outputs without damage to the stove and its electrical components.

## **Will a Harman pellet stove heat my home?**

One of the first questions we hear from people looking for a stove is “Will a Harman pellet stove heat my home?” The answer is more involved than a simple yes or no.

The fact is, there are thousands of homeowners throughout the Northeast who rely on Harman pellet stoves to heat their homes and to become less dependent on fossil fuels. Some heat a single room, some all first floor living areas or a finished basement and others do heat their entire home.

The total area that you will be able to heat with a pellet stove will depend on the following factors:

- ◆ how tight and well insulated your home is
- ◆ how cold it is where you live
- ◆ where the stove is located within your home
- ◆ the layout of your home
- ◆ which stove model you choose

Here is a list of typical applications:

- living rooms and dining rooms
- den & family rooms
- sunrooms with large doorways to main house
- insulated basements
- upstairs of garage
- home offices
- garage conversions (no garages with cars)
- workshops
- 1<sup>st</sup> & 2<sup>nd</sup> floors of some homes
- basement, 1<sup>st</sup> floor of ranch or cape

## How large a Harman pellet stove do I need?

How large a stove you will need depends on the size of your home and whether your home has an open floor plan or many small rooms. Pellet stoves rely on the movement of warm air to heat the living area, therefore the better the air moves within the living area or between rooms, the larger the area the stove will heat. In a raised ranch for instance, where there is a large open stairway from the basement to the first floor it may be possible to heat an entire home when the stove is located in the basement because air rises freely up into the first floor living areas. Conversely, it would be difficult to heat an entire home when the stove is located at the far end of the house and there are small rooms throughout the living area (Fig. 1). Open floor plans work the best (Fig. 2), but if your house has a number of adjoining rooms, the stoves will likely heat more than the room that it is in. In this case some rooms will be warmer than others.

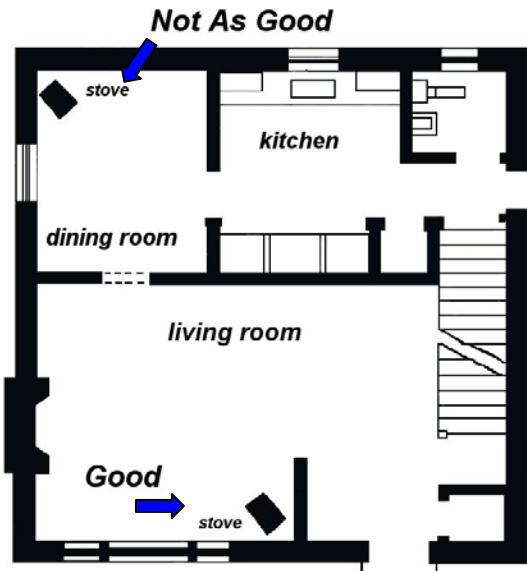

Fig. 1

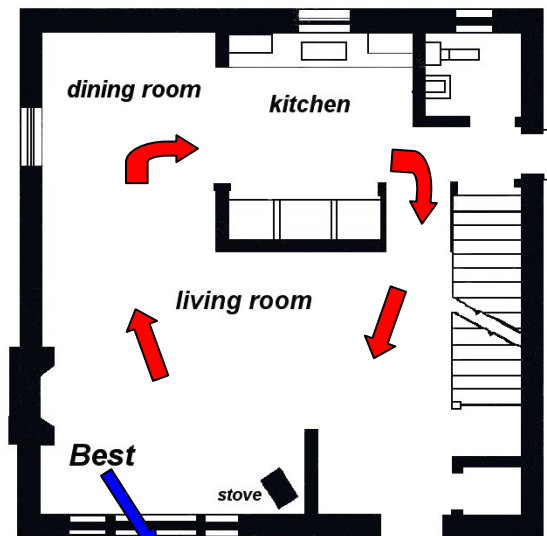

Fig. 2

Open Floor Plan

## Stove Sizing Chart

The chart shown below should serve as a general guideline for the sq. ft. heating capacity of each model. The chart provides ranges for tight houses and for older less insulated homes based on typical heating needs. If you are buying a stove as a supplementary heat source to augment your central heating system any Harman model will do the job.

Each model is capable of burning 1 to 2 bags of pellets per day which is the typical heat output range for most homes. If you plan to rely on the stove as your primary source of heat be conservative and choose one of the higher heating models. The higher heating models like the Advance, P61, P61A and P68 will give you the extra horsepower to heat even on the coldest days of winter.

## Guidelines for Sizing Harman Pellet Stoves

Pellet Stove  Stove Model	BTU/Hour  Min/Max Range	Heating Requirements in Northeast		Heating Capacity Rating
		<i>Well insulated Home</i> (20 BTU/sq. ft.)	<i>Older less tight home</i> (40 BTU/sq. ft.)	
P-61	8,000 to 61,000	3050 sq. ft.	1525 sq. ft.	up to 2000 sq. ft.
P61A	0 to 61,000	3050 sq. ft.	1525 sq. ft.	up to 2000 sq. ft.
P68	0 to 68,000	3400 sq. ft.	1700 sq. ft.	up to 2200 sq. ft.
Invincible Insert	7 to 53,000	2650 sq. ft.	1325 sq. ft.	up to 1800 sq. ft.
Advance	0 to 48,000	2400 sq. ft.	1200 sq. ft.	up to 1800 sq. ft.
P38+	7,000 to 43,000	2150 sq. ft.	1075 sq. ft.	up to 1700 sq. ft.
Accentra	0 to 40,000	2000 sq. ft.	1000 sq. ft.	up to 1700 sq. ft.
Accentra Insert	0 to 42,000	2000 sq. ft.	1000 sq. ft.	up to 1700 sq. ft.

## **Here are some other factors to consider when choosing a Harman pellet stove:**

◆ Don't use the physical size of a stove to determine whether a stove is right for a given area. Refer to the Guidelines Chart and advice from your authorized Harman dealer to determine whether the stove is right for your application.

With the auto-ignition models you have a great deal of flexibility with respect to room size because they can automatically shut off to prevent overheating of the space.

◆ Be careful not to put a pellet stove in too small a room unless there is a way to move the heat into outlying rooms. A stand alone 12 ft. X 12 ft. room for instance would be too small.

◆ Heating needs for houses in the Northeast are generally between 20 and 40 BTU's/sq. ft. per hour according to some heating specialists. Some super insulated homes require less than 20 BTU's per sq. ft., while some leaky farmhouses may require 60 BTU's per sq. ft.. If your home is tight, but not particularly well insulated you might choose 30 BTU's per sq. ft. as your heating requirement. To determine the size stove you will need, take the number of square feet you plan to heat and multiply this number by 30 BTU's.

Example: 30 ft. X 40 ft. = 1200 sq. ft. x 30 BTU's per square foot = 36,000 BTU's. Based on this calculation and the assumptions you have made about how tight your house is, any Harman model would heat this area. (Again, this assumes adequate air movement.)

◆ Harman pellet stoves are the highest heating stoves on the market, but they cannot defy the laws of physics. Don't expect a pellet stove located in an uninsulated basement to heat an entire house. Too much heat will be absorbed by the concrete or stone walls.

◆ During the Spring and Fall pellet stoves will heat larger areas and often even the smallest model will heat an entire home. As the weather becomes progressively colder, the total maximum square footage a stove will heat will diminish.

◆ The higher the BTU output of the stove, the more area the stove will heat at the maximum output. In the coldest areas of New England and New York where the coldest days of winter are -25°F to -35° F below zero the larger BTU models are ideal. (Advance, P61, P61A, P68) Also these models are good for heating larger areas & rooms with high ceilings in warmer climates. Many homeowners have installed P61's & P61A's in insulated basements and used them to heat the first floor of their homes.

◆ Most homeowners burn a bag of pellets in a 24 hour period. On cold days 2 to 3 bags may be needed to heat larger areas. During the spring and fall it is common to burn ½ bag per day or less depending on the area that is being heated. Most homeowners are burning 3 to 4 tons of pellets a year. This is 150 to 200 40 lb. bags. Large homes will likely need between 5 and 8 tons per year.

Generally it takes approximately 2 tons of pellets per 1,000 sq. ft per season for the home. If you have 1500 sq. ft., it will take 3 tons of pellets.

◆ Some pellet stove manufacturers inflate the heating capacity sq. ft. ratings of their stoves. Homeowners always ask us “Why will brand X’s 32,000 BTU/hr heat stove heat more area than Harman’s 40,000 BTU/hr model? The answer is that Brand X’s stove cannot. Harman’s ratings are realistic for the Northeast where heating demands are great.

## **Venting requirements to consider when you are choosing a location for your Harman Pellet stove.**

One of the factors that should be considered in determining the best location for your new Harman pellet stove is the location and configuration of the vent pipe. Both stove performance and maintenance can be adversely affected if the stove is not vented properly. There are also aesthetic concerns. Some homeowners are replacing woodstoves and don't mind seeing vent pipe in the room, others prefer that the vent pipe be located on the outside of the house.

Harman pellet stoves are very versatile with respect to venting. There are three typical configurations that are commonly used; chimney venting, "partial" chimney venting and horizontal direct venting. Each has pluses and minuses yet all three configurations work well and are commonly used throughout the Northeast.

### **Chimney Venting**

Chimney Venting is when you use an existing chimney or create your own chimney using pellet vent pipe (PL vent).

Existing tile lined masonry chimneys or prefabricated Class A metal chimneys provide excellent venting because they help naturally draw the exhaust gases up and out of the house. In this configuration there must be no other appliances vented into the same flue. (This does preclude an oil burner or woodstove from using another flue within the same chimney) The chimney must be in good working order and be free of cracks, open seams or holes. Relining using 4" or larger rigid or flexible stainless steel liner may be recommended by your authorized Harman dealer if there is any doubt that the chimney is suitable to vent a pellet stove. In some cases relining is done to eliminate potential draft problems caused by an oversized flue or to make the venting system easier to inspect and clean. Any chimney that is to be used must be inspected and cleaned prior to installation of your Harman pellet stove.

Many Harman dealers have the experience and equipment to reline the chimney if this is necessary. Alternatively they may recommend a National Fireplace Institute (NFI) Certified Specialist or a CSIA Certified Chimney Sweep who can do the work.

The advantage of using a chimney is that it will draw smoke from the firebox of the stove in the event of a power outage.

Pellet vent pipe (also known as PL vent) is constructed of two layers of steel with an air space in between layers. The inner liner is stainless steel and the outer casing is galvalume. The air space acts as an insulator and reduces the outside surface temperature to allow a clearance to combustibles of only 3 inches. The sections of pipe lock together, but sealing the joints is essential. Below you will see examples of the many ways to vent a pellet stove.

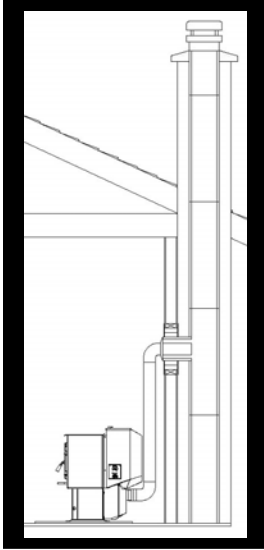

PL vent is used as a connector pipe between the stove and the masonry chimney.

PL vent pipe is used to connect the stove to a chimney liner that has been installed within a tile lined masonry chimney.

A wall thimble is used to shield the pellet vent where it passes through a combustible wall in front of the chimney.

Relining the chimney is essential when the chimney is old and has no tile liner or has a cracked tile liner.

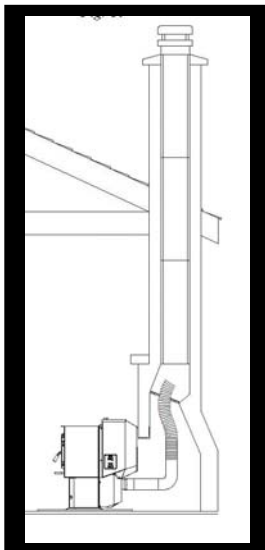
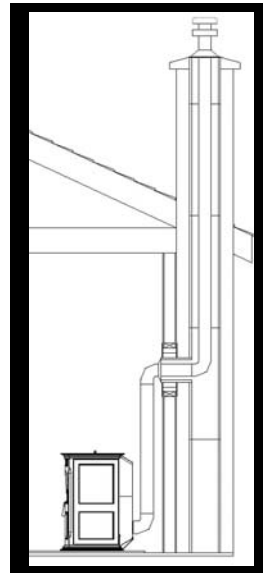

Stove is installed in front of a masonry fireplace. Vent pipe extends above the damper to just below the tile liner of the chimney.

Flexible vent pipe is used above the 90° elbow. A seal is made with insulation or with metal at or near the damper location.

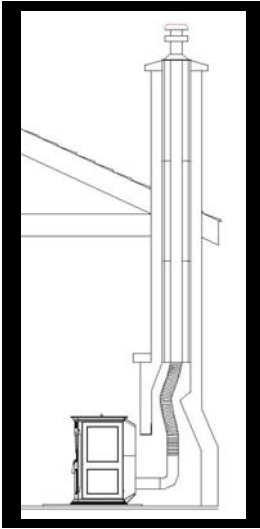

A full liner is used to reline the chimney. The liner generally allows the flue to be easily cleaned.

In addition, the liner may prevent draft problems that are caused by oversized flues.

PL vent is used from the stove up through the ceiling and through the roof of the home.

A ceiling support and other components are used to protect combustible framing members in the ceiling.

Each PL vent manufacturer has specific components that are to be used in this installation configuration.

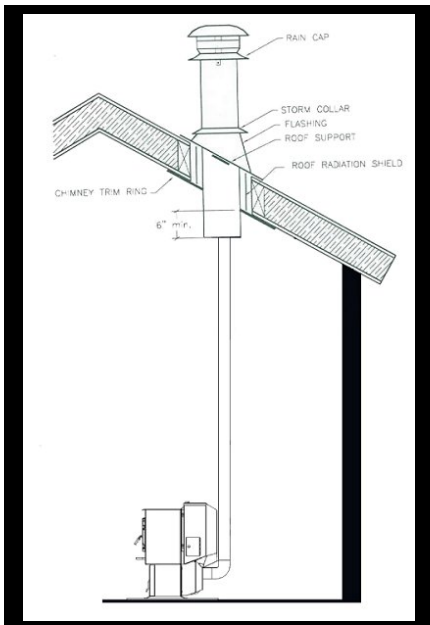
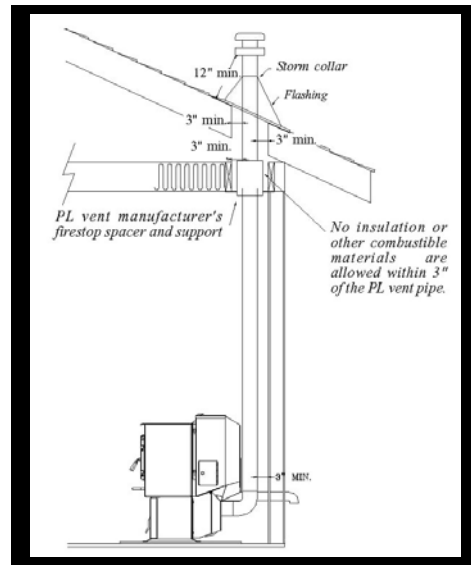

In this installation PL vent pipe is used as a connector pipe between the stove and a Class A All Fuels chimney.

A reducer will be needed to go from the pellet vent to the larger Class A Chimney

## “Partial” Chimney Venting

Partial chimney venting is when PL vent is used to create a 4 ft. or higher vent. The advantage of this installation configuration is that it helps evacuate smoke from the firebox of the stove in the event of a power failure. In addition various pipe configurations can be used to move the exhaust termination away from windows and other obstructions such as shrubs.

PL vent is used within the home to create rise. A tee or 90° elbow may be used behind the stove and a wall thimble is used to pass through the exterior combustible wall.

The termination of the vent pipe must be at least 12 inches from the side of the house. An outside air kit is shown.

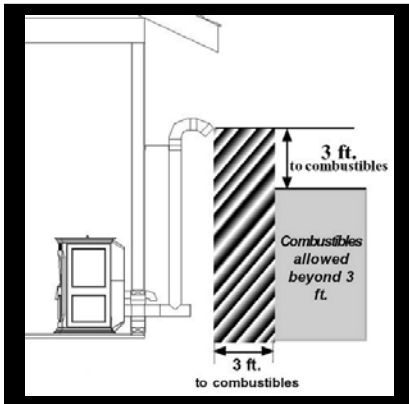
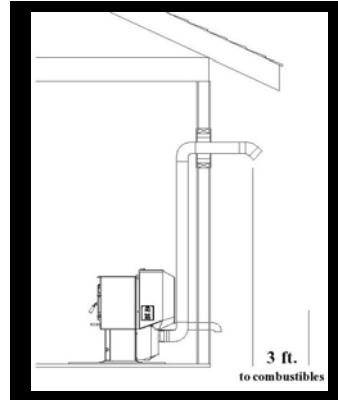

Here the PL vent pipe goes horizontally out and then up about 4 ft.

Note that the tee on the outside is positioned so that the horizontal section of the pipe can be cleaned by removing a cap on the end of the tee. An outside air kit is shown.

## Horizontal Direct Venting

Horizontal Direct Venting is the easiest configuration to clean since the horizontal section of pipe can be cleaned through the exhaust port within the stove. This configuration is considered the minimum flue vent configuration by Harman. It is recommended that an outside air kit be installed to reduce smoke and creosote smell in the room in the event of a power failure. The outside air kit will greatly reduce, but not eliminate the smell of smoke when the power goes out.

Note that there is a 24” clearance between the termination of the PL vent pipe and the ground. A 45° elbow is shown for the last section of pipe. A horizontal termination cap or a “Turbo” cap can be used in place of the elbow. The outside air kit is shown at right. Alternatively you can use the Harman Direct Vent Wall Pass-through Kit which simplifies the installation process.

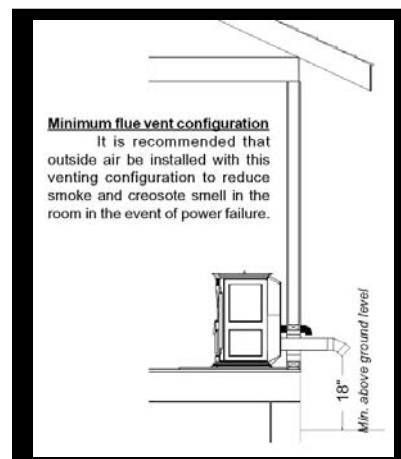

## Direct Vent Wall Pass-Through Kit

Harman's Direct Vent Wall Pass-Through Kit allows you to safely pass through a combustible wall and at the same time bring fresh outside air for combustion. All of this is accomplished with a single 6 1/2" x 6 1/2" hole cut in the wall.

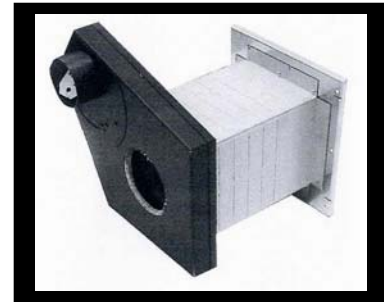

The center hole as shown to the right is for the 3" pellet vent and the upper left opening accommodates a 3/8" flex pipe which is connected to the air intake collar at the back of the stove and is used as a fresh air intake. This upper left opening connect to the stove's air inlet via a flexible pipe. Another advantage of providing air to the stove is that you can position the pellet vent termination within 18" of an operable door or window versus 4 feet. Your clearance from the vent termination to grade is just 24". It's recommended that if you decide to terminate the minimum of 24" to grade that you use patio block underneath for mulch and combustible material protection.

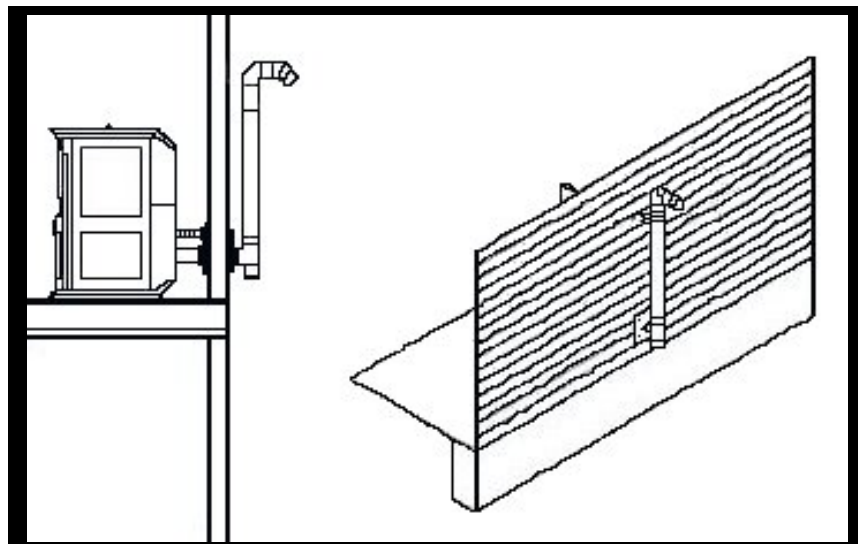
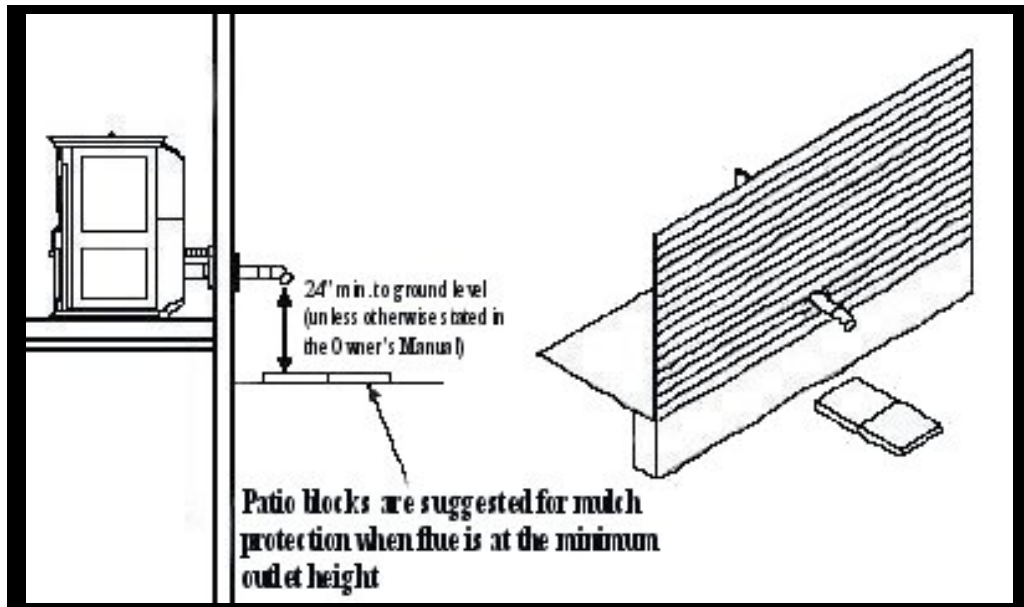

## Important Tips and Safety Considerations

Here are some general rules which will help you avoid some common venting problems. It is important that you refer to both these guidelines and your **Harman Stove Owners Manual** during the planning stage of the installation.

◆ We recommend that you have your stove professionally installed by your local Authorized Harman dealer or alternatively an NFI (National Fireplace Institute) Certified installer.

◆ If you are planning to do the installation yourself, review your Harman Stove **Owners Manual** and the tips below first. If you have any questions ask your Harman dealer before you begin. Draft related problems can occur when the venting is not configured properly. Smoking or creosote smell in the room can occur when the joints in the pipe are not fully sealed. Improper clearances for the stove or the vent pipe can cause house fires or worse still, loss of life.

◆ The vent pipe termination must be at least four feet (4 ft.) from an operable window or door unless an outside air kit is installed and there must be clearance to combustible materials such as trees and shrubs. In addition there may be local or state codes that apply to pellet stove installations in your area. The diagrams below show clearances to the vent termination to combustible materials:

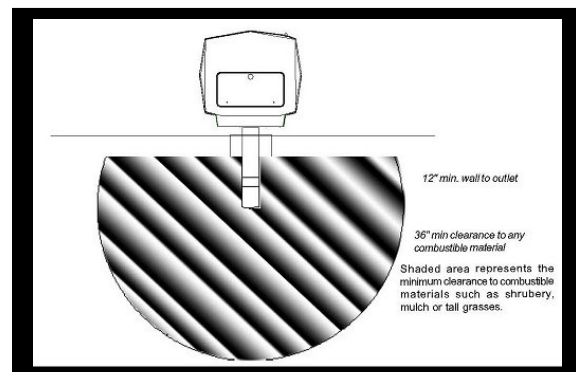
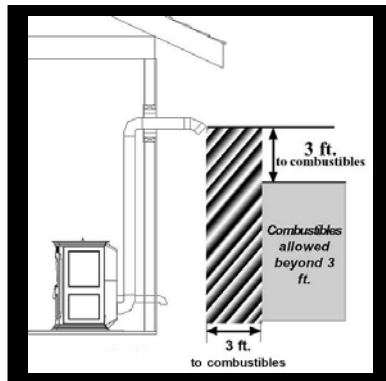

◆ Outside air kits are required for mobile homes and some building codes. Outside air is recommended for tight energy efficient homes. Either the kit shown below or the Direct Vent Wall Pass-through Kit may be used for this purpose.

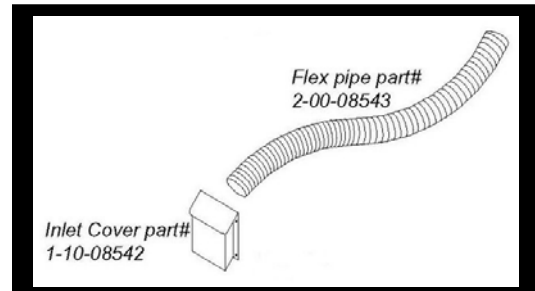
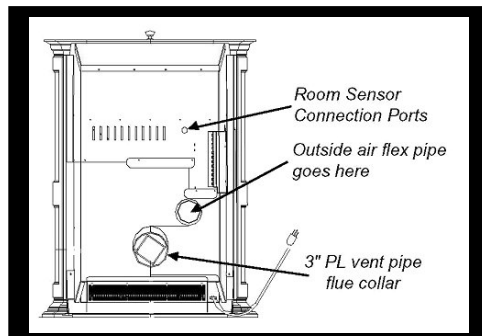

◆ Harman pellet stoves utilize a combustion blower to “push” exhaust out into the flue thus drawing air into the stove; as a result there is positive pressure in the venting system.

For this reason all seams and joints in the pellet vent pipe (Called PL Vent) should be sealed with silicone caulk, silicone tape or alternatively metal tape, and then checked for leaks after the stove is installed. (Aluminum tape is not recommended within 6” of the stove’s outlet, due to high temperatures in this area).

If the joints and seams are not sealed carefully you will smell smoke in the room where the stove is located.

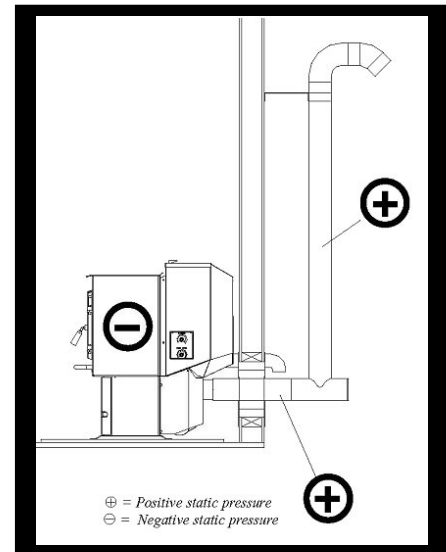

◆ Never use B Vent or aluminum dryer pipe or mix and match brands of pellet pipe to vent your stove. Aluminum pipe will melt at high temperatures. The inner liner of pellet vent pipe (PL vent) is stainless steel for this reason.

◆ Even though pellet stoves burn cleanly, all venting systems, including the chimney will need to be inspected and cleaned once per year. For this reason it is important to design your venting system in such a way that certain joints can be taken apart for cleaning. This can be accomplished by applying high temperature silicone to the outside of joints that will be taken apart and to the inside of joints that will not.

In this way you can cut off the silicone with a knife and unscrew the pipe. Aluminum tape may also be used on joints that will need to be taken apart, but not within the first 6” of pipe near the stove.

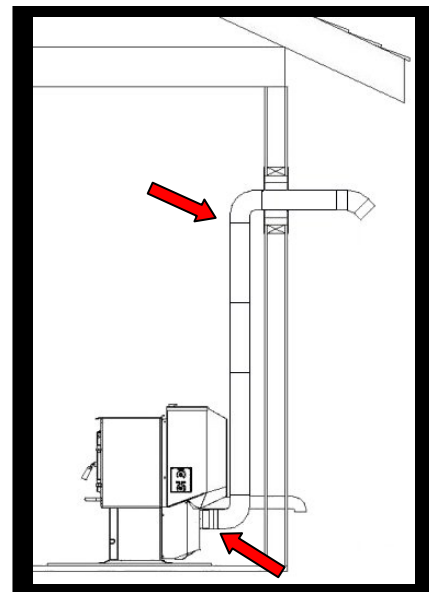

◆ The longer the vent pipe and more elbows used in the system the greater the flow resistance. We recommend as few elbows as possible (2 or 3 are OK, but 4 may be too many depending on the length of pipe between elbows) and 15 ft or less of vent pipe. 45° elbows are better than 90° elbows. The maximum horizontal run should not exceed 48”. If elbows and longer runs are unavoidable upsize to 4” PL Vent.

◆ Be sure to maintain proper clearances to the pellet pipe and the stove. Generally pellet pipe has a 3” clearance and there are special components such as wall radiation shields that you must use when passing through a combustible wall. The P38, P61, P61A, and

the P68 have optional side heat shields which allow you to reduce clearance at the sides of the stoves.

***Important Note:*** Be sure to allow enough room at the sides and back of the stove so that blowers and other components can be reached for cleaning and servicing. This may mean increasing the clearances from the minimum specified by Harman in order to have this access room.

◆ Harman pellet stoves are clean burning, but staining on the outside of the house can occur if the vent pipe termination is too close to the side of the house. This can also happen if winds blow the exhaust back against the house.

Staining can usually be easily removed with household detergents, but the potential problem can be eliminated entirely by keeping the vent pipe termination farther away. (2 ft. instead of the 1 ft. minimum)

Some installers use 45° elbows to direct the products of combustion away from the house, others use “Turbo” caps which blow straight out. Vinyl siding picks up a static charge and draws the small soot particles to it. Some installers recommend spraying Scotch Guard around the termination area so that the siding can be cleaned more easily.

◆ Be sure to fasten the first length of PL vent pipe to the flue outlet of the stove with at least 2 fasteners. In addition we recommend that you fasten each pipe joint with at least 1 TEK screw. Never put a PL vent pipe joint within a wall thimble or other place where it will be hidden.

◆ Installations in garages (where cars are parked) and bedrooms are prohibited.

◆ Harman recommends that the draft be checked on each pellet stove installation. The reason for this is to be sure that the draft is within specific ranges. This will ensure proper venting and efficient operation of the stove. Most common installation configurations provided in the illustrations above work well without any changes, but occasionally the low draft setting on the circuit board will need to be adjusted.

Taking a draft reading will verify proper operation and whether the low draft setting requires adjustment. Draft is measured using a manometer which samples air pressure inside of the fire chamber. Each Harman Owners manual describes the procedure.

# Requirements for Terminating the Venting

## Requirements for Terminating the Venting

**WARNING:** Venting terminals must not be recessed into a wall or siding.

**NOTE:** Only PL vent pipe wall pass-throughs and fire stops should be used when venting through combustible materials.

**NOTE:** Always take into consideration the effect the prevailing wind direction or other wind currents will cause with flyash and /or smoke when placing the termination.

**In addition, the following must be observed:**

A. The clearance above grade must be a minimum of 18".<sup>1</sup>

B. The clearance to a window or door that may be opened must be a minimum of 48" to the side, 48" below the window/door, and 12" above the window/door.<sup>1</sup>

(with outside air installed, 18")

C. A 12" clearance to a permanently closed window is recommended to prevent condensation on the window.

D. The vertical clearance to a ventilated soffit located above the terminal within a horizontal distance of 2 feet (60 cm) from the center-line of the terminal must be a minimum of 18".

E. The clearance to an unventilated soffit must be a minimum of 12".

F. The clearance to an outside corner is 11" from center of pipe.

G. The clearance to an inside corner is 12".

H. A vent must not be installed within 3 feet (90 cm) above a gas meter/regulator assembly when measured from the horizontal center-line of

the regulator.<sup>1</sup>

I. The clearance to service regulator vent outlet must be a minimum of 6 feet.<sup>1</sup>

J. The clearance to a non-mechanical air supply inlet to the building or the combustion air inlet to any other appliance must be a minimum of 48".<sup>1</sup>

K. The clearance to a mechanical air supply inlet must be a minimum of 10 feet.<sup>1</sup>

(with outside air installed, 6 feet)

L. The clearance above a paved sidewalk or a paved driveway located on public property must be a minimum of 7 feet.<sup>1,2</sup>

M. The clearance under a veranda, porch, deck or balcony must be a minimum of 12 inches.<sup>1,3</sup>

**NOTE:** The clearance to vegetation and other exterior combustibles such as mulch is 36" as measured from the center of the outlet or cap. This 36" radius continues to grade or a minimum of 7 feet below the outlet.

<sup>1</sup>Certain Canadian and or Local codes or regulations may require different clearances.

<sup>2</sup>A vent shall not terminate directly above a side-walk or paved driveway which is located between two single family dwellings and serves both dwellings.

<sup>3</sup>Only permitted if veranda, porch, deck, or balcony is fully open on a minimum of 2 sides beneath the floor.

**NOTE: Where passage through a wall, or partition of combustible construction is desired, the installation shall conform to CAN/CSA-B365. (if in Canada)**

